

REVISION HISTORY			
REV	DESCRIPTION	DATE	APPROVED
0	FIRST RELEASE	01/11/08	
1	UPDATED	2/10/09	

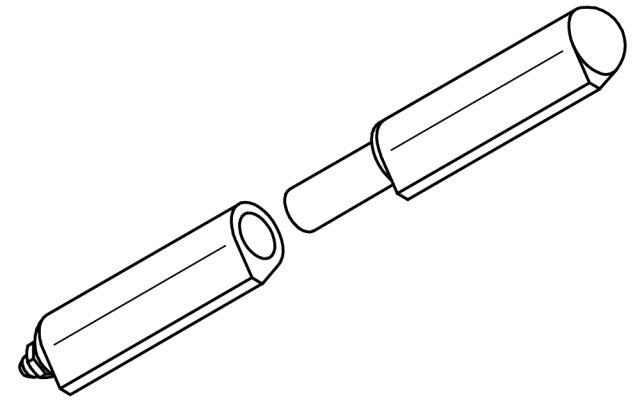
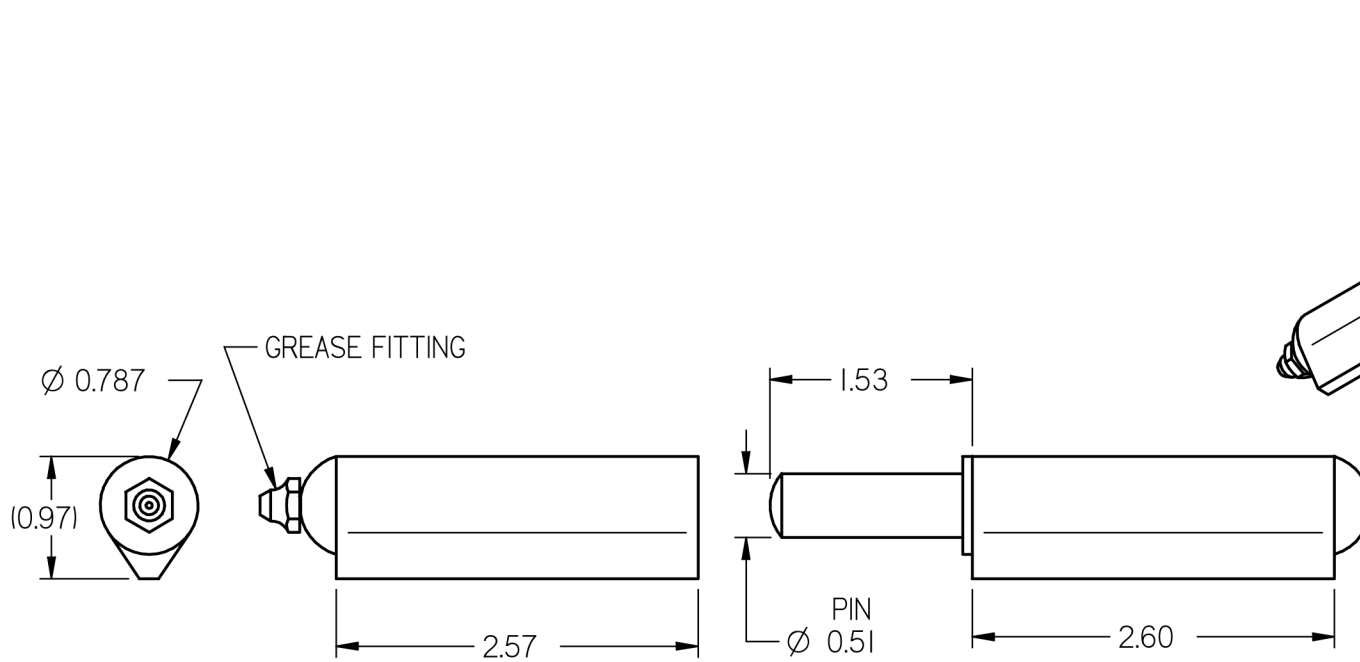

NOTES:

1. MATERIAL: PLAIN STEEL WITH BRASS WASHER, BRASS GREASE FITTING
2. FINISH: NONE
3. ASSEMBLED LENGTH: 5.86

		DRAWN	NAME	DATE
		CHECKED	TOM	01/11/08
<small>CE DOCUMENT CONTIENT DE L'INFORMATION CONFIDENTIELLE PROTEGEE EN DROIT. TOUTE REPRODUCTION, DISTRIBUTION, UTILISATION OU COMMUNICATION DE CE DOCUMENT OU DE SON CONTENU SANS CONSENTEMENT EXPRESS SONT STRICTEMENT INTERDITES.</small> <small>THIS DOCUMENT CONTAINS CONFIDENTIAL PROPRIETARY INFORMATION. THE REPRODUCTION, DISTRIBUTION, UTILISATION OR THE COMMUNICATION OF THIS DOCUMENT OR ANY PART THEREOF, WITHOUT EXPRESS AUTHORISATION IS STRICTLY FORBIDDEN.</small>		DWG NO		REV
		PSI50SPGF		I
<small>REMOVE ALL BURRS & BREAK ALL SHARP EDGES</small>		TITLE		
		WELD-ON HINGE		
<small>ALL DIMENSIONS ARE IN INCHES UNLESS OTHERWISE SPECIFIED</small>		TOLERANCES		<small>THIRD ANGLE PROJECTION</small>
		XX	± 0.060	
<small>REMOVE ALL BURRS & BREAK ALL SHARP EDGES</small>		XXX	± 0.030	<small>SHEET 1 OF 1</small>
		XXXX	± 0.015	
<small>REMOVE ALL BURRS & BREAK ALL SHARP EDGES</small>		ANGLES	$\pm 1.0^\circ$	<small>SHEET 1 OF 1</small>
		HOLES	± 0.005	