

REVISION HISTORY			
REV	DESCRIPTION	DATE	APPROVED
0	FIRST RELEASE	01/11/08	
1	UPDATED	2/10/09	

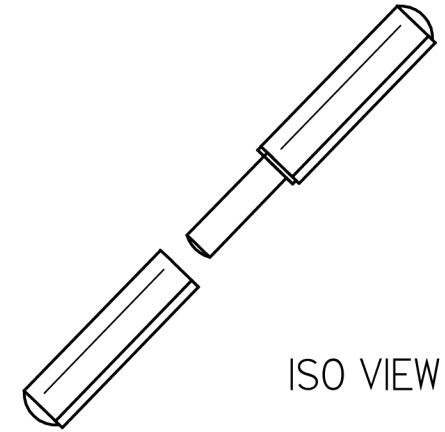
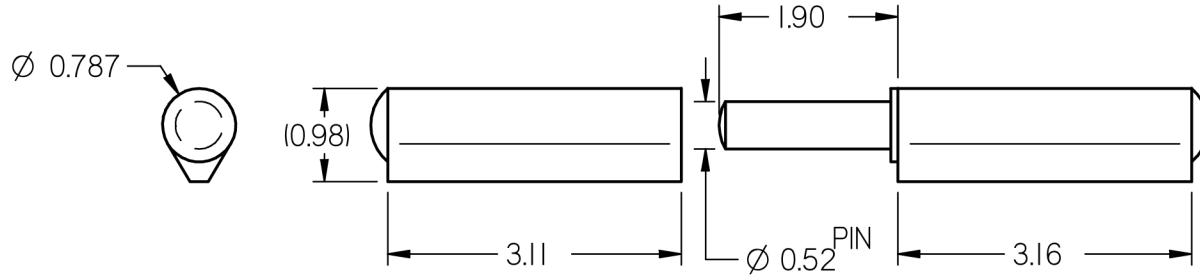

ISO VIEW

NOTES:

1. MATERIAL: PLAIN STEEL WITH BRASS PIN & WASHER.
2. FINISH: NONE
3. ASSEMBLED LENGTH: 7.07

		DRAWN	NAME	DATE	
		CHECKED	TOM	01/11/08	
<small>CE DOCUMENT ANSI OU SON CONTENU SONT LA PROPRIETE DE QUICALLERE INDUSTRIELLE NORMONT L.TEE. CE DOCUMENT CONTIENT DE L'INFORMATION CONFIDENTIELLE PROTEGEE EN DROIT. TOUTE REPRODUCTION, DISTRIBUTION, UTILISATION OU COMMUNICATION DE CE DOCUMENT OU DE SON CONTENU SANS CONSENTEMENT EXPRESS SONT STRICTEMENT INTERDITES. THIS DOCUMENT AND ITS CONTENTS ARE THE PROPERTY OF NORMONT INDUSTRIAL HARDWARE LTD. THIS DOCUMENT CONTAINS CONFIDENTIAL PROPRIETARY INFORMATION. THE REPRODUCTION, DISTRIBUTION, UTILISATION OR THE COMMUNICATION OF THIS DOCUMENT OR ANY PART THEREOF, WITHOUT EXPRESS AUTHORISATION IS STRICTLY FORBIDDEN.</small>		DWG NO	PSI80BP	REV	
		TITLE	WELD-ON HINGE		
REMOVE ALL BURRS & BREAK ALL SHARP EDGES	ALL DIMENSIONS ARE IN INCHES UNLESS OTHERWISE SPECIFIED	TOLERANCES		THIRD ANGLE PROJECTION 	SCALE
		X.X	±0.060		N.T.S.
		XXX	±0.030		SIZE
		XXXX	±0.015		B
		ANGLES	±1.0°	SHEET 1 OF 1	
		HOLES	±0.005		