

REVISION HISTORY			
REV	DESCRIPTION	DATE	APPROVED
0	FIRST RELEASE	01/11/08	
1	UPDATED	2/10/09	

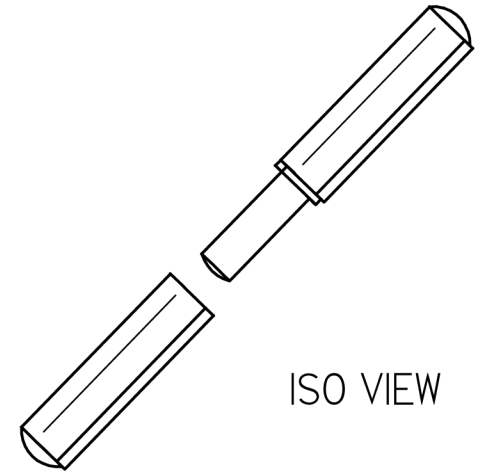
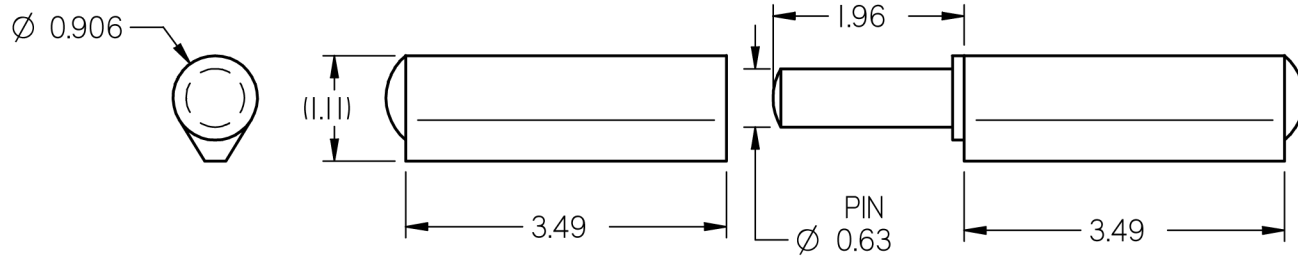

ISO VIEW

NOTES:

1. MATERIAL: PLAIN STEEL WITH BRASS WASHER
2. FINISH: NONE
3. ASSEMBLED LENGTH: 7.90

	DRAWN	NAME	DATE										
	CHECKED	TOM	01/11/08										
<small>CE DOCUMENT ANSI QUE SON CONTENU SONT LA PROPRIETE DE QUICALLERE INDUSTRIELLE NORMONT L.TEE. CE DOCUMENT CONTIENT DE L'INFORMATION CONFIDENTIELLE PROTEGEE EN DROIT. TOUTE REPRODUCTION, DISTRIBUTION, UTILISATION OU COMMUNICATION DE CE DOCUMENT OU DE SON CONTENU SANS CONSENTEMENT EXPRESS SONT STRICTEMENT INTERDITES. THIS DOCUMENT AND ITS CONTENTS ARE THE PROPERTY OF NORMONT INDUSTRIAL HARDWARE LTD. THIS DOCUMENT CONTAINS CONFIDENTIAL PROPRIETARY INFORMATION. THE REPRODUCTION, DISTRIBUTION, UTILISATION OR THE COMMUNICATION OF THIS DOCUMENT OR ANY PART THEREOF, WITHOUT EXPRESS AUTHORISATION IS STRICTLY FORBIDDEN.</small>	DWG NO	PS200SP	REV										
	TITLE	WELD-ON HINGE											
	TOLERANCES	<table border="1"> <tr><td>XX</td><td>±0.060</td></tr> <tr><td>XXX</td><td>±0.030</td></tr> <tr><td>XXXX</td><td>±0.015</td></tr> <tr><td>ANGLES</td><td>±1.0°</td></tr> <tr><td>HOLES</td><td>±0.005</td></tr> </table>	XX	±0.060	XXX	±0.030	XXXX	±0.015	ANGLES	±1.0°	HOLES	±0.005	THIRD ANGLE PROJECTION
XX	±0.060												
XXX	±0.030												
XXXX	±0.015												
ANGLES	±1.0°												
HOLES	±0.005												
REMOVE ALL BURRS & BREAK ALL SHARP EDGES ALL DIMENSIONS ARE IN INCHES UNLESS OTHERWISE SPECIFIED			N.T.S. SIZE B										
		SHEET 1 OF 1											